

aSLC

Mini SATA III Module

PHANES-HR Series

Supports DRAM Cache

(JEDEC MO-300A)

Document No. : 100-xBMSR-PHCTMBAS

Version No. : 02V1

Date: March, 2020

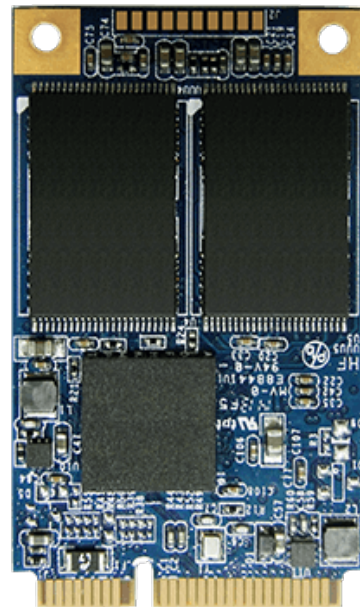

ISO 9001 : 2015 CERTIFIED



Product Features

■ Flash IC

- TOSHIBA 15nm NAND Flash IC.
- Multi-Level Cell (MLC) management by enhance endurance technology (aSLC)

■ Compatibility

- SATA Revision 3.2
- SATA 1.5Gb/s; SATA 3Gb/s & SATA 6Gb/s data transfer rate.
- ATA-8 ACS2 command set

■ Additional Capabilities

- S.M.A.R.T.*¹ (Self-Monitoring, Analysis and Reporting Technology) feature set support.
- Thermal Monitor for SSD's temperature.
- Native Command Queuing (NCQ) support.
- TRIM maintenance command support.
- Both Static & Dynamic wear-leveling algorithm

■ Mechanical

- JEDEC MO-300A full size Solid State Drive
- 52 pos. Edge Connector, PCI Express (PCIe) mini
- Dimension: 50.8 mm x 29.85 mm.
- Weight: 8.0 g / 0.28 oz.

■ Power Operating Voltage +3.3V±5%

- Read Mode: 2,380.0 mW (max.)
- Write Mode: 3,620.0 mW (max.)
- Idle Mode: 270.0 mW (max.)

■ Performance (Maximum value) *²

- Sequential Read: 550.0 MB/sec. (max.)
- Sequential Write: 510.0 MB/sec. (max.)
- 4KB Random Read IOPS (QD32): 72.0K
- 4KB Random Write IOPS (QD32): 90.0K
- 4KB Random Read access time: 0.11ms
- 4KB Random Write access time: 0.06ms

■ Capacity

- 8GB, 16GB, 32GB, 64GB, 128GB and 256GB

■ Reliability

- **TBW:** Up to 5,136 TBW at 256GB Capacity. (Test by Sequential Write)
- **ECC:** Automatic 120 bits per 2K bytes error correction (ECC) and retry capabilities
- **Temperature:** (Operating)
Standard Grade: 0°C ~ +70°C
Wide Temp. Grade: -40°C ~ +85°C
- **Vibration:** 80 Hz to 2000 Hz, 20G, 3 axes.
- **Shock:** 0.5ms, 1500 G, 3 axes

■ Certifications and Declarations

- **Certifications:** CE & FCC
- **Declarations:** RoHS & REACH

Remarks:

1. Support official S.M.A.R.T. Utility.
2. Sequential performance is based on CrystalDiskMark 5.1.2 with file size 1000MB

Order Information

I. Part Number List

◆ APRO aSLC Mini SATA III Module (mSATA) PHANES-HR Series

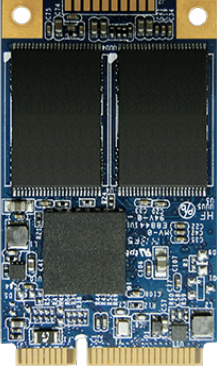
Product Picture	Grade	Standard grade (0°C ~ 70°C)	Wide Temp Grade (-40°C ~ +85°C)
	32GB	SBMSR032G-PHCTMBAS	WBMSR032G-PHCTMBASC
	64GB	SBMSR064G-PHCTMBAS	WBMSR064G-PHCTMBASC
	128GB	SBMSR128G-PHCTMBAS	WBMSR128G-PHCTMBASC
	256GB	SBMSR256G-PHCTMBAS	WBMSR256G-PHCTMBASC

Notes:

C : Special conformal coating treated on whole PCBA which may support wide temp. grade operating temperature -40°C ~ +85°C

II. Part Number Decoder:

X1 X2 X3 X4 X5 X6 X7 X8 X9 X11 X12 X13 X14 X15 X16 X17 X18 X19 X20

X1 : Grade

S: Standard Grade – operating temp. 0° C ~ 70 ° C

W: Wide Temp Grade- operating temp. -40° C ~ +85 ° C

X2 : The material of case

B : Bare PCBA w/o Casing

X3 X4 X5 : Product category

MSM : mini SATA III Module

X6 X7 X8 X9 : Capacity

032G: 32GB **256G:** 256GB

064G: 64GB

128G: 128GB

X11 : Controller

P : PHANES Series

X12 : Controller version

A, B, C.....

X13 : Controller Grade

C : Commercial grade

X14 : Flash IC

T : Toshiba NAND Flash IC

X15 : Flash IC grade / Type

M : MLC-NAND flash IC

X16 :Flash IC

B : Toshiba 15nm MLC

X17 X18 : aSLC Technology

AS : aSLC Technology extends MLC product's lifespan

X19 X20 : Reserved for specific requirement

C : Conformal-coating (optional)

Revision History

Revision	Description	Date
1.0	Initial release.	2018/11/08
1.1	Updated Version	2018/11/28
2.0	Updated document form	2019/05/30
2.1	Remove 512GB Capacity	2020/03/18

Contents

Product Features	- 2 -
Order Information	- 3 -
I. Part Number List	- 3 -
II. Part Number Decoder:	- 3 -
Revision History	- 4 -
Contents	- 5 -
1. Introduction	- 6 -
1.1. Scope	- 7 -
1.2. aSLC Technology	- 7 -
1.3. Flash Management Technology - Static & Dynamic Wear Leveling	- 7 -
1.4. Bad Block Management	- 8 -
2. Product Specifications	- 8 -
2.1. System Environmental Specifications	- 8 -
2.2. System Power Requirements	- 8 -
2.3. System Performance	- 9 -
2.4. System Reliability	- 9 -
2.5. Physical Specifications	- 10 -
2.6. Conformal coating	- 11 -
3. Interface Description	- 11 -
3.1. Mini SATA III Module interface	- 11 -
3.2. Pin Assignments	- 12 -
Appendix A: Limited Warranty	- 13 -

1. Introduction

APRO aSLC Mini SATA III Module (mSATA) PHANES-HR Series provides high capacity flash memory Solid State Drive (SSD) that electrically complies with SATA Revision 3.2 standard. APRO aSLC Mini SATA III Module (mSATA) PHANES-HR Series support SATA 1.5Gb/s; SATA 3Gb/s & SATA 6Gb/s data transfer rate with high performance. It is designed with mSATA form factor by JEDEC MO-300A standard, and the available disk capacities are 32GB, 64GB, 128GB and 256GB. The operating temperature grade is optional for Standard grade 0°C ~ 70°C and wide temp grade with conformal coating supports -40°C ~ +85°C.

APRO aSLC Mini SATA III Module (mSATA) PHANES-HR Series provide the ultra-high random speed for heavy-loading embedded or server operations with space constraints for host computing systems; the performance of sequential read is up to 550.0 MB/sec. (max.), and sequential write is up to 510.0 MB/sec. (max.).

APRO aSLC Mini SATA III Module (mSATA) PHANES-HR Series products provide a high level interface to the host computer. This interface allows a host computer to issue commands to the mSATA module to read or write blocks of memory. Each sector is protected by a powerful 120 bits per 2K bytes error correction (ECC). APRO aSLC Mini SATA III Module (mSATA) PHANES-HR Series intelligent controller manages interface protocols, data storage and retrieval as well as ECC, defect handling and diagnostics, power management and clock control.

Figure 1 shows a block diagram of the APRO aSLC Mini SATA III Module (mSATA) PHANES-HR Series.

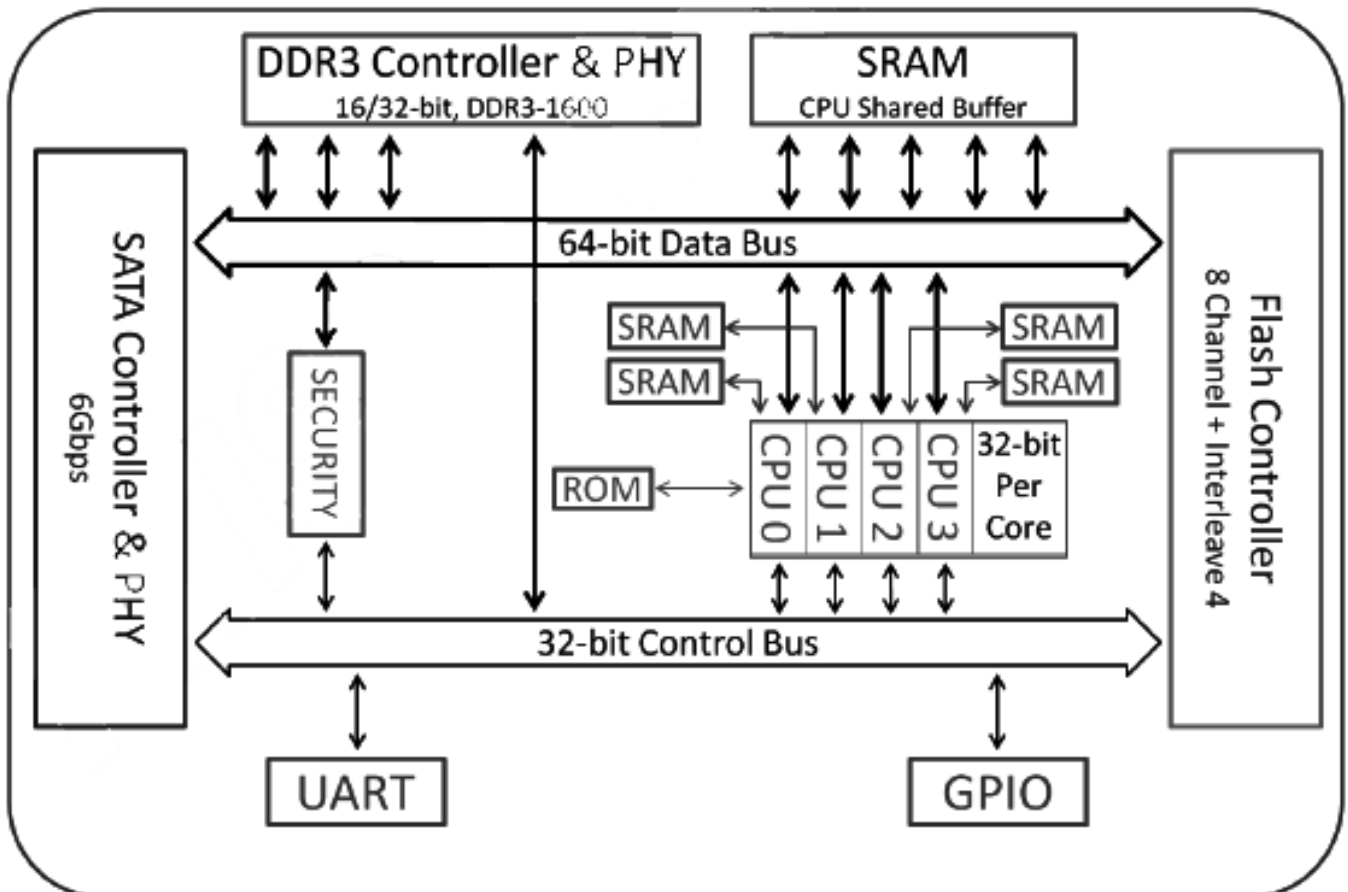

Figure 1: APRO aSLC Mini SATA III Module (mSATA) PHANES-HR Series block diagram

1.1. Scope

This document describes features, specifications and installation guide of APRO aSLC Mini SATA III Module (mSATA) PHANES-HR Series. In the appendix, there provides order information, warranty policy, RMA/DOA procedure for the most convenient reference.

1.2. aSLC Technology

The aSLC can be considered as an extended version of the MLC. While MLC contains both fast and slow pages, aSLC only utilizes fast pages for programming. The concept of aSLC is demonstrated in the **Figure 2** below. The first and second bits of a memory cell represent a fast and slow page respectively, as shown in the left table. Since only fast pages are programmed when applying aSLC, the bits highlighted in red are used, as shown in the right table. As a result, aSLC provides better performance and endurance than MLC does. Moreover, the aSLC performs similarly to the SLC, yet more cost effective.

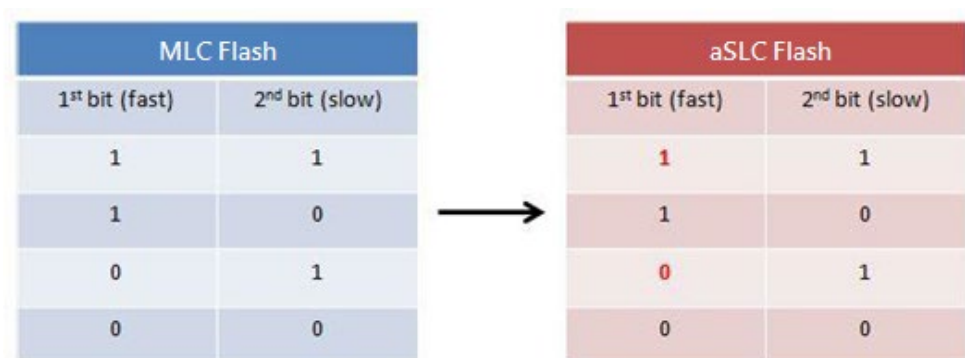

Figure 2: The concept of APRO aSLC Mini SATA III Module (mSATA) PHANES-HR Series

1.3. Flash Management Technology - Static & Dynamic Wear Leveling

NAND flash devices can only undergo a limited number of program/erase cycles, and in most cases, the flash media are not used evenly. If some areas get updated more frequently than others, the lifetime of the device would be reduced significantly. Thus, Wear Leveling is applied to extend the lifespan of NAND Flash by evenly distributing write and erase cycles across the media.

APRO aSLC Mini SATA III Module (mSATA) PHANES-HR Series provides advanced Wear Leveling algorithm, which can efficiently spread out the flash usage through the whole flash media area. Moreover, by implementing both dynamic and static Wear Leveling algorithms, the life expectancy of the NAND flash is greatly improved.

1.4. Bad Block Management

➤ Early Bad Block

The fault block generated during the manufacturing process of NAND Flash is called Early Bad Block.

➤ Later Bad Block

In the process of use, as the number of operations of writing and erasing increases, a fault block is gradually generated, which is called a Latter Bad Block.

Bad block management is a management mechanism for a bad block to be detected by the control IC and mark bad blocks in the NAND Flash and improve the reliability of data access. The bad block management mechanism of the control IC will establish a **Bad Block Table** when the NAND Flash is started for the first time, and will also record the errors found in the process of use in the bad block table, and data is ported to new valid blocks to avoid data loss.

In order to detect the initial bad blocks to handle run time bad blocks, APRO aSLC Mini SATA III Module (mSATA) PHANES-HR Series provides the **Bad Block Management** scheme. It remaps a bad block to one of the reserved blocks so that the data contained in one bad block is not lost and new data writes on a bad block is avoided.

2. Product Specifications

For all the following specifications, values are defined at ambient temperature and nominal supply voltage unless otherwise stated.

2.1. System Environmental Specifications

Table 1: Environmental Specification

APRO aSLC Mini SATA III Module (mSATA) PHANES-HR Series		Standard Grade SBMSRxxxG-PHCTMAS	Wide Temp Grade WBMSRxxxG-PHCTMAS-C
Temperature	Operating:	0°C ~ +70°C	-40°C ~ +85°C
	Non-operating:	-20°C ~ +80°C	-50°C ~ +95°C
Humidity	Operating & Non-operating:	10% ~ 95% non-condensing	
Vibration	Frequency/Acceleration:	80 Hz to 2000 Hz, 20G, 3 axes	
Shock	Operating & Non-operating:	0.5ms, 1500 G, 3 axes	
Electrostatic Discharge (ESD)	Temperature:	24°C	
	Relative Humidity:	49% (RH)	
	+/-4KV:	Device functions are affected, but EUT will be back to its normal or operational state automatically.	

2.2. System Power Requirements

Table 2: Power Requirement

APRO aSLC Mini SATA III Module (mSATA) PHANES-HR Series		
DC Input Voltage (VCC)		+3.3V±5%
Maximum average value	Reading Mode :	2,380.0 mW (max.)
	Writing Mode :	3,620.0 mW (max.)
	Idle Mode :	270.0 mW (max.)

2.3. System Performance

Table 3: System Performances

Data Transfer Mode supporting		Serial ATA Gen-III (6.0Gb/s = 768MB/s)				
4KB Random access time	Read:	0.11 ms.				
	Write:	0.06 ms.				
Maximum Performance	Capacity	32GB	64GB	128GB	256GB	
	Sequential Read (MB/s)	550.0	550.0	550.0	550.0	
	Sequential Write (MB/s)	300.0	490.0	500.0	510.0	
	4KB Random Read IOPS (QD32)	72.0K	72.0K	72.0K	72.0K	
	4KB Random Write IOPS (QD32)	75.0K	90.0K	90.0K	90.0K	

Note:

- The performance was measured using CrystalDiskMark v5.0x64 with SATA 6Gbps host.
- Performance may differ according to flash configuration, SDR configuration, and platform.
- The table above is for reference only. The criteria for MP (mass production) and for accepting goods shall be discussed based on different flash configuration.

2.4. System Reliability

Table 4: System Reliability

Wear-leveling Algorithms		Static and Dynamic wear-leveling algorithms
Bad Block Management		Supportive
ECC Technology		120 bits per 2K bytes
Erase counts		NAND MLC Flash w/aSLC Technology : 20K P/E Cycles
TBW (Tera Bytes Written)		
Capacity	32GB	642.0
	64GB	1,284.0
	128GB	2,568.0
	256GB	5,136.0

Note:

- The test by sequential write.
- TBW may differ according to flash configuration and platform.
- The endurance of SSD could be estimated based on user behavior, NAND endurance cycles, and write amplification factor.
It is not guaranteed by flash vendor.

2.5. Physical Specifications

Refer to Table 5 and see Figure 2 for APRO aSLC Mini SATA III Module (mSATA) PHANES-HR Series physical specifications and dimensions.

Table 5: Physical Specifications of APRO aSLC Mini SATA III Module (mSATA) PHANES-HR Series

Length:	50.8 mm
Width:	29.85 mm
Weight:	8.0 g / 0.28 oz.

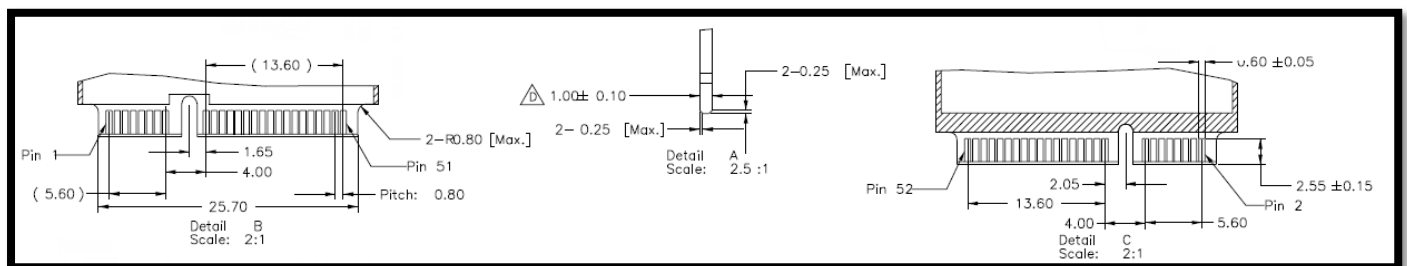
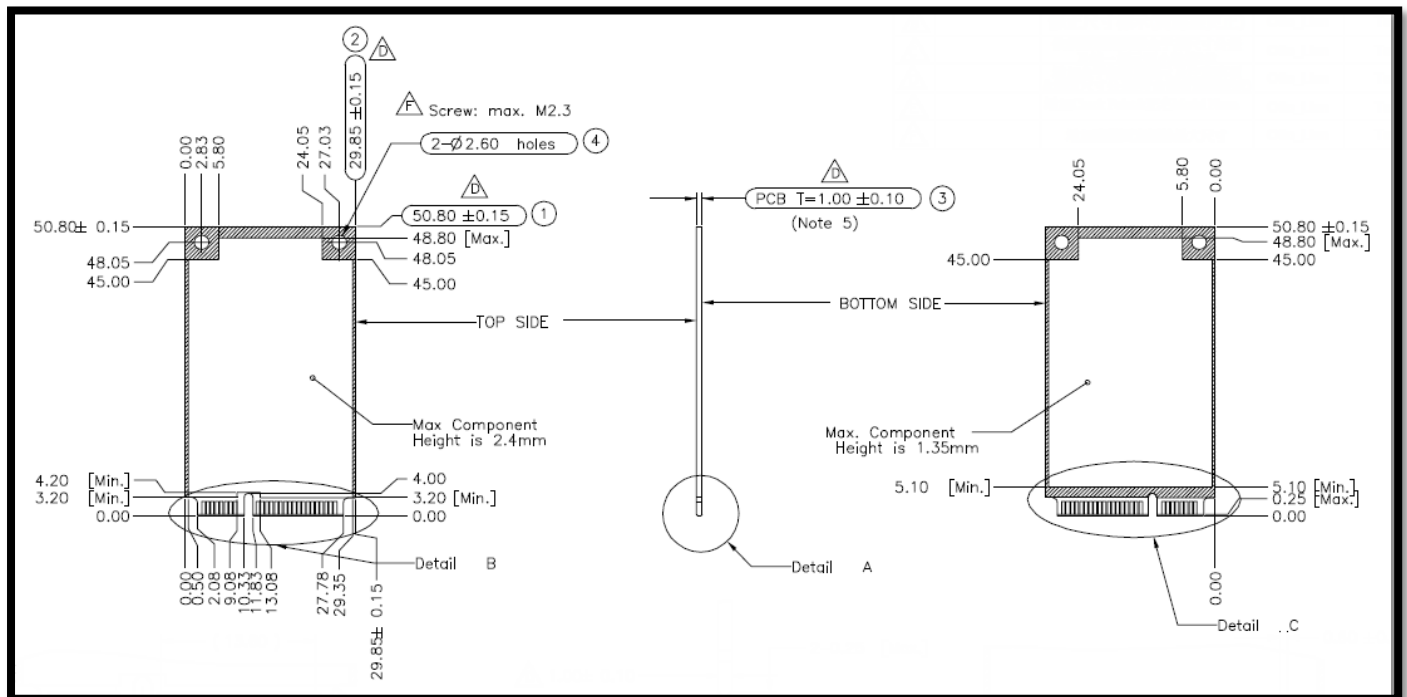

Figure 3: APRO Mini SATA III Module (JEDEC MO-300A) Dimension

2.6. Conformal coating

Conformal coating is a protective, dielectric coating designed to conform to the surface of an assembled printed circuit board. Commonly used conformal coatings include silicone, acrylic, urethane and epoxy. APRO applies only silicone on APRO storage products upon requested especially by customers. The type of silicone coating features good thermal shock resistance due to flexibility. It is also easy to apply and repair.

Conformal coating offers protection of circuitry from moisture, fungus, dust and corrosion caused by extreme environments. It also prevents damage from those Flash storages handling during construction, installation and use, and reduces mechanical stress on components and protects from thermal shock. The greatest advantage of conformal coating is to allow greater component density due to increased dielectric strength between conductors.

APRO use MIL-I-46058C silicon conformal coating

3. Interface Description

3.1. Mini SATA III Module interface

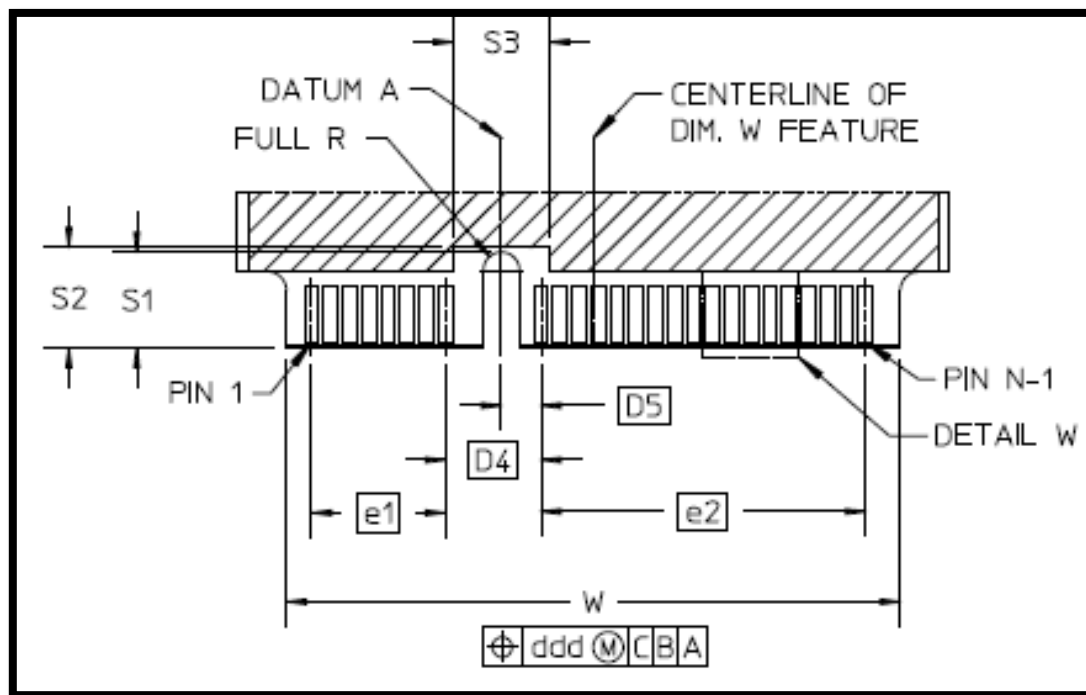

Figure 4: The connectors of Signal Segment and Power Segment

3.2. Pin Assignments

APRO aSLC Mini SATA III Module (mSATA) PHANES-HR Series operates with standard SATA pin-out.

The pin assignments are listed in below table 6.

Table 6 - Pin Assignments

Signal Name	Pin #	Pin #	Signal Name
NC	1	2	+3.3V
NC	3	4	DGND
NC	5	6	NC
NC	7	8	NC
DGND	9	10	NC
NC	11	12	NC
NC	13	14	NC
DGND	15	16	NC
NC	17	18	DGND
NC	19	20	NC
SATA GND	21	22	NC
TX+	23	24	+3.3V
TX-	25	26	SATA GND
SATA GND	27	28	NC
SATA GND	29	30	NC
RX-	31	32	NC
RX+	33	34	DGND
SATA GND	35	36	NC
SATA GND	37	38	NC
+3.3V	39	40	DGND
+3.3V	41	42	NC
NC	43	44	DEVSLP
NC	45	46	NC
NC	47	48	NC
DAS	49	50	DGND
GND	51	52	+3.3V

Appendix A: Limited Warranty

APRO warrants your aSLC Mini SATA III Module (mSATA) PHANES-HR Series against defects in material and workmanship for the life of the drive. The warranty is void in the case of misuse, accident, alteration, improper installation, misapplication or the result of unauthorized service or repair. The implied warranties of merchantability and fitness for a particular purpose, and all other warranties, expressed or implied, except as set forth in this warranty, shall not apply to the products delivered. In no event shall APRO be liable for any lost profits, lost savings or other incidental or consequential damages arising out of the use of, or inability to use, this product.

BEFORE RETURNING PRODUCT, A RETURN MATERIAL AUTHORIZATION (RMA) MUST BE OBTAINED FROM APRO.

Product shall be returned to APRO with shipping prepaid. If the product fails to conform based on customers' purchasing orders, APRO will reimburse customers for the transportation charges incurred.

WARRANTY PERIOD:

- **aSLC (Standard grade / Wide temp. grade) 2 years / Within 20K Erasing Counts**

This document is for information use only and is **subject to change without prior notice**. APRO Co., Ltd. assumes no responsibility for any errors that may appear in this document, nor for incidental or consequential damages resulting from the furnishing, performance or use of this material. No part of this document may be reproduced, transmitted, transcribed, stored in a retrievable manner or translated into any language or computer language, in any form or by any means, electronic, mechanical, magnetic, optical, chemical, manual or otherwise, without the prior written consent of an officer of APRO Co., Ltd.

All parts of the APRO documentation are protected by copyright law and all rights are reserved.

APRO and the APRO logo are registered trademarks of APRO Co., Ltd.

Product names mentioned herein are for identification purposes only and may be trademarks and/or registered trademarks of their respective companies.

© 2018 APRO Corporation. All rights reserved