

SLC

SATA III 1.8" Flash SSD

PHANES-K Series

Document No. : 100-xP8SF-PKTS

Version No. : 01V0

Date : September, 2020



ISO 9001 : 2015 CERTIFIED



Product Features

■ Flash IC

- TOSHIBA NAND Flash IC.
- Single-Level Cell (SLC) management

■ Compatibility

- Compliant with SATA Revision 3.2
- SATA 1.5Gbps/3.0Gbps/6.0Gbps data transfer rate.
- ATA-8 ACS4 command set

■ Additional Capabilities

- S.M.A.R.T.*1 (Self-Monitoring, Analysis and Reporting Technology) feature set support.
- Native Command Queuing (NCQ) support.
- TRIM maintenance command support.
- Both Static & Dynamic wear-leveling algorithm
- Hardware Low Density Parity Check Code, LDPC support.
- Support bad Block Management
- Support DIPM/HIPM Mode for power saving

■ Mechanical

- micro SATA 7 pins (data) + 9 pins (power connector) host Interface
- 1.8" form-factor (shorter than PCMCIA Type II form-factor)
- Dimension: 54.0 mm x 78.5 mm x 5.0 mm.
- Weight: 25g /0.88oz.

■ Power Operating Voltage 3.3V(+/-) 5%

- Read Mode: 2,110.0 mW (max.)
- Write Mode: 2,230.0 mW (max.)
- Idle Mode: 310.0 mW (max.)

■ Performance (Maximum value) *2

- Sequential Read: 470.0 MB/sec. (max.) *2
- Sequential Write: 420.0 MB/sec. (max.) *2

■ Capacity

- 8GB, 16GB, 32GB, 64GB and 128GB

■ Reliability

- **TBW:** Up to 2,133 TBW at 128GB Capacity.
(Client workload by JESD-219A)
- **MTBF:** > 3,000,000 hours.
- **ECC:** Designed with hardware LDPC ECC engine with hard-decision and soft-decision decoding.
- **Temperature:** (Operating)
Standard Grade: 0°C ~ +70°C
Wide Temp. Grade: -40°C ~ +85°C
- **Vibration:** 80 Hz to 2000 Hz, 20G, 3 axes.
- **Shock:** 0.5ms, 1500 G, 3 axes.

■ Certifications and Declarations

- **Certifications:** CE & FCC
- **Declarations:** RoHS & REACH

Remarks:

1. Support official S.M.A.R.T. Utility.
2. Sequential performance is based on CrystalDiskMark 5.1.2 with file size 1000MB

Order Information

I. Part Number List

◆ APRO SLC micro SATA III SSD PHANES-K Series

Product Picture	Grade	Standard grade (0°C ~ 70°C)	Industrial Grade (-40°C ~ +85°C)
	8GB	SP8SF008G-PKCTC	WP8SF008G-PKITI
	16GB	SP8SF016G-PKCTC	WP8SF016G-PKITI
	32GB	SP8SF032G-PKCTC	WP8SF032G-PKITI
	64GB	SP8SF064G-PKCTC	WP8SF064G-PKITI
	128GB	SP8SF128G-PKCTC	WP8SF128G-PKITI

Notes:

C : Special conformal coating treated on whole PCBA which may support industrial grade operating temperature -40°C ~ +85°C

II. Part Number Decoder:

X1 X2 X3 X4 X5 X6 X7 X8 X9 X11 X12 X13 X14 X15 - C

X1 : Grade

S: Standard Grade – operating temp. 0° C ~ 70 ° C

W: Industrial Grade- operating temp. -40° C ~ +85 ° C

X2 : The material of case

P : Plastic frame kit

X3 X4 X5 : Product category

8SF : 1.8" micro SATA III SSD

X6 X7 X8 X9 : Capacity

008G: 32GB **064G:** 64GB

016G: 16GB **128G:** 128GB

032G: 32GB

X11 : Controller

P : PHANES Solution

X12 : Controller version

A, B, C.....

X13 : Controller Grade

C : Commercial grade

I : Industrial grade

X14 : Flash IC

T : Toshiba NAND Flash IC

X15 : Flash IC grade / Type

C : Commercial grade

I : Industrial grade

C : Reserved for specific requirement

C : Conformal-coating

Revision History

Revision	Description	Date
1.0	Initial release.	2020/9/17

Contents

Product Features	- 2 -
Order Information	- 3 -
I. Part Number List	- 3 -
II. Part Number Decoder:	- 3 -
Revision History	- 4 -
Contents	- 5 -
1. Introduction	- 6 -
1.1. Scope	- 7 -
1.2. Flash Management Technology – Static & Dynamic Wear Leveling	- 7 -
1.3. Bad Block Management	- 7 -
1.4. Mean Time Between Failure (MTBF)	- 8 -
1.4.1. Definition	- 8 -
1.4.2. Obtaining MTBF	- 8 -
1.4.3. Definitions	- 9 -
2. Product Specifications	- 11 -
2.1. System Environmental Specifications	- 11 -
2.2. System Power Requirements	- 11 -
2.3. System Performance	- 11 -
2.4. System Reliability	- 12 -
2.5. Physical Specifications	- 12 -
2.5.1. Conformal coating	- 13 -
3. Interface Description	- 14 -
3.1. micro SATA III SSD interface	- 14 -
3.2. Pin Assignments	- 15 -
Appendix A: Limited Warranty	- 16 -

1. Introduction

APRO SLC 1.8" micro SATA III SSD PHANES-K Series provides high capacity flash memory Solid State Drive (SSD) that electrically complies with SATA Revision 3.2 standard; APRO SLC 1.8" micro SATA III SSD PHANES-K Series support SATA 1.5Gb/s; SATA 3Gb/s & SATA 6Gb/s data transfer rate with high performance.

The available disk capacities are from 8GB up to 128GB. The operating temperature grade is optional for Standard grade 0°C ~ 70°C and Industrial Grade with conformal coating supports -40°C ~ +85°C.

APRO SLC 1.8" micro SATA III SSD PHANES-K Series is suitable to handheld device embedded system, inventory recorder and particularly for serious environment monitor recorder system. The sequential read speed is 470 MB/sec and sequential write speed is 420 MB/se which were testing based on 128GB capacity

APRO SLC 1.8" micro SATA III SSD provides a high level interface to the host computer. This interface allows a host computer to issue commands to the APRO SLC 1.8" micro SATA III SSD PHANES-K Series to read or write blocks of memory. A powerful hardware design is architecture multiplied LDPC (Low Density Parity Check) for Error Correcting Coding (ECC).

APRO SLC 1.8" micro SATA III SSD PHANES-K Series intelligent controller manages interface protocols, data storage and retrieval as well as ECC, bad block management and diagnostics, power management and clock control.

Figure 1 shows a block diagram of the used high tech micro SATA III SSD controller.

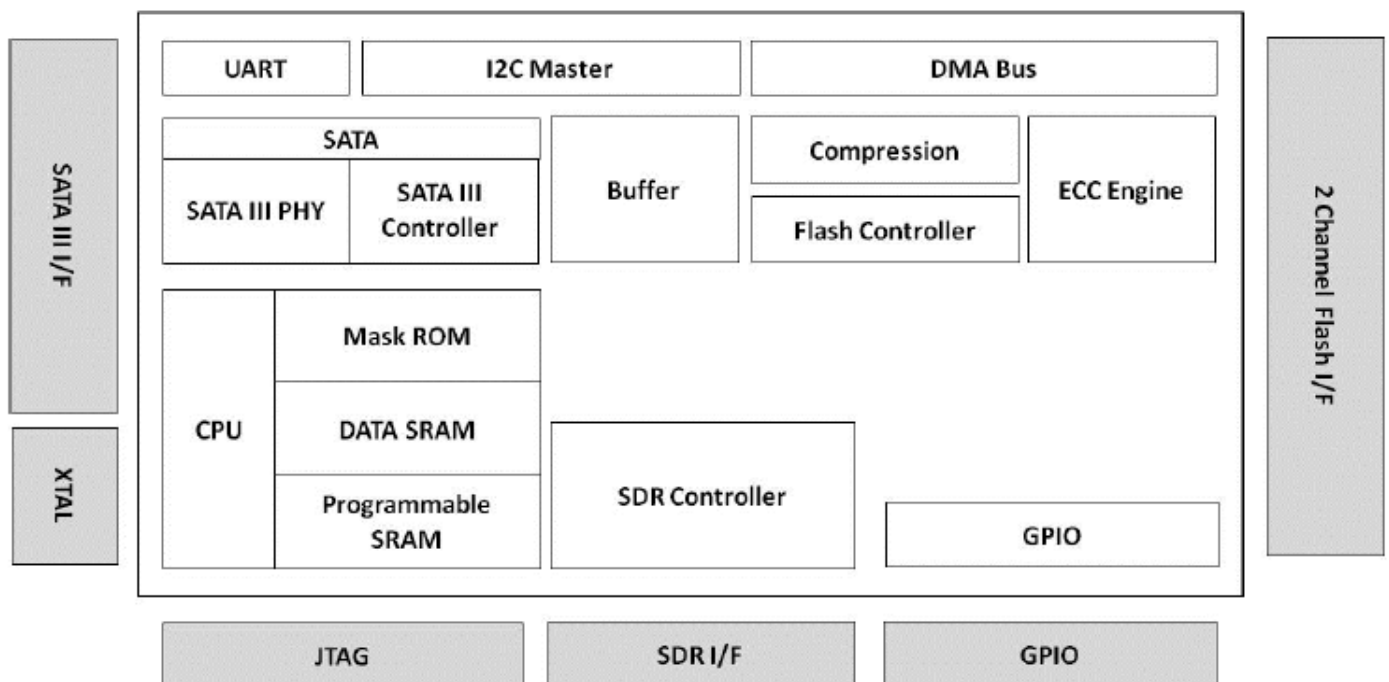

Figure 1: APRO SLC micro SATA III SSD PHANES-K Series block diagram

1.1. **Scope**

This document describes features, specifications and installation guide of APRO SLC 1.8" micro SATA III SSD PHANES-K Series. In the appendix, there provides order information, warranty policy, RMA/DOA procedure for the most convenient reference.

1.2. **Flash Management Technology – Static & Dynamic Wear Leveling**

NAND flash devices can only undergo a limited number of program/erase cycles, and in most cases, the flash media are not used evenly. If some areas get updated more frequently than others, the lifetime of the device would be reduced significantly. Thus, Wear Leveling is applied to extend the lifespan of NAND Flash by evenly distributing write and erase cycles across the media.

APRO SLC 1.8" micro SATA III SSD PHANES-K Series provides advanced Wear Leveling algorithm, which can efficiently spread out the flash usage through the whole flash media area. Moreover, by implementing both dynamic and static Wear Leveling algorithms, the life expectancy of the NAND flash is greatly improved.

1.3. **Bad Block Management**

➤ **Early Bad Block**

The fault block generated during the manufacturing process of NAND Flash is called Early Bad Block.

➤ **Later Bad Block**

In the process of use, as the number of operations of writing and erasing increases, a fault block is gradually generated, which is called a Latter Bad Block.

Bad block management is a management mechanism for a bad block to be detected by the control IC and mark bad blocks in the NAND Flash and improve the reliability of data access. The bad block management mechanism of the control IC will establish a **Bad Block Table** when the NAND Flash is started for the first time, and will also record the errors found in the process of use in the bad block table, and data is ported to new valid blocks to avoid data loss.

In order to detect the initial bad blocks to handle run time bad blocks, APRO SLC 1.8" micro SATA III SSD PHANES-K Series provides the **Bad Block Management** scheme. It remaps a bad block to one of the reserved blocks so that the data contained in one bad block is not lost and new data writes on a bad block is avoided.

1.4. Mean Time Between Failure (MTBF)

1.4.1. Definition

MTBF (Mean time between failures) is defined as failure or maintenance required for the average time including failure detection and maintenance for the device. For a simple and maintainable unit, $MTBF = MTTF + MTTR$.

MTTF (mean time to failure) is defined as the expectation of random variables for time to failure.

MTTR (mean time to restoration) is the expectation of random variables of time required for restoration which includes the time required for confirmation that a failure occurred, as well as the time required for maintenance.

1.4.2. Obtaining MTBF

There are two methods for obtaining MTBF:

A. MTBF software estimation method: by calculating all the MTBF data of all the components included in the bill of material, and the data of the completed products including actual parameters of voltage and electrical current using analysis software, the MTBF of the completed product is estimated.

B. MTBF sample test method: by determining a certain number of samples and a fixed time for testing, using a Arrhenius Model and Coffin-Manson Model to obtain parameters, and then using the formula with the parameters, the longevity and in so the reliability is proved.

Arrhenius Model: $Af = e\{ (1/k \times Ea (1/273+Tmax - 1/273+Ttest))\}$

Coffin-Manson Model: $Af = (\Delta Ttest/\Delta Tuse)m$

➤ **APRO uses the A method to Estimate MTBF**

MTBF is actually obtained by calculation which is just an estimation of future occurrences. The main reason to use the first method is that the data contains the analysis by all the parameters of components and actual parameters of voltage and electrical current of finished products, which is considered adequate and objective.

➤ **Interpretation of MTBF Analysis**

APRO estimates MTBF using a prediction methodology based on reliability data for the individual components in APRO products. The predicted MTBF based on Parts stress analysis Method of Telcordia Special Report SR-332, for components failure rates. Component data comes from several sources: device life tests, failure analysis of earlier equipment, device physics, and field returns.

The Telcordia model is based on the Telcordia document, Reliability Prediction Procedure for Electronic Equipment, Technical Reference SR-332. This standard basically modified the component models in MIL-HDBK-217 to better reflect the failure rates that AT&T Bell Lab equipment was experiencing in the field and was originally developed by AT&T Bell Lab as the Bellcore model.

This model supports different failure rate calculation methods in order to support the taking into account of stress, burn-in, laboratory, or field data. A Parts Count or Parts Stress analysis is included in Telcordia performance. Relex supports Telcordia Issues 1 and 2 and also Bellcore Issues 4, 5, and 6. Telcordia Issue 2, released in September 2006, are supported by Relex and Telcordia Issue 1, released in May 2001, is replaced with Relex. Refer to Telcordia Issue 2 Fields for information about the fields in Relex Reliability Studio specific to Telcordia Issue 2.

➤ Purpose of the analyses

The purpose of these analyses is to obtain early estimation of device reliability during engineering and customer validation stages. The prediction results will expose the reliability of whole assembly, viewed as a set of serially connected electronic components. Rating of the assembly electronic components will show the ratio between actual critical elements parameters and their specification limits. The purpose of component rating is to improve a product's inherent design reliability, increase its number of operating times, and to reduce warranty costs and to achieve a more robust design.

1.4.3. Definitions

Term	Definition
Failure	The event, or inoperable state, in which any item or part of an item does not, or would not, perform as previously specified.
Failure rate	The total number of failures within an item population, divided by the total number of life units expended by that population, during a particular measurement interval under stated condition.
FIT	Failures In Time: the number of failures in 1 billion hours.
PPM	Part per million: the number of failures in 1 million hours.
Mean Time Between Failures (MTBF)	A basic measure of reliability for repairable items: The mean number of life units during which all parts of the item perform within their specified limits, during a particular measurement interval under stated conditions..
GB	Ground, Fixed, Controlled: Nearly zero environmental stress with optimum engineering operation and maintenance. Typical applications are central office, environmentally controlled vaults, environmentally controlled remote shelters, and environmentally controlled customer premise area.
GF	Ground, Fixed, Uncontrolled: Some environmental stress with limited maintenance. Typical applications are manholes, poles, remote terminals, and customer premise areas subject to shock, vibration, temperature, or atmospheric variations.

➤ Software & Database

Analysis Software & Analysis Method

Software Name : Relex Reliability Studio 2008

Software Version : Relex Studio 2008

Analysis Method

The prediction method used was Telcordia SR-332, Issue 2,

Parts Count

Failure rate (λ) = 10^9 hours (FITs)

MTBF=1/ λ

$\lambda_{SSi} = \lambda_{Gi} \cdot TT_{Qi} \cdot TT_{Si} \cdot TT_{Ti}$

Where λ_{Gi} : Generic steady-state failure rate for device i

TT_{Qi} : Quality factor for device i

TT_{Si} : Stress factor for device i

TT_{Ti} : Temperature factor for device i

➤ **Calculation Parameter**

Operation Temperature : 25°C

Environment : Ground Benign, Controlled

Operation Stress : 50% (Voltage, Current, Power)

Method : Method I, Case 3

Products are advertised with MTBF up to 1 million hours in the market. Take one million hours as an example, the product's estimated life is 114 years. However, the current rapid progress of technology, advancement of flash storage device's manufacturing process research and development, and the supply period of former flash IC manufacturing processes are crucial to the actual life expectancy of flash products. In short, the MTBF of flash storage is for reference only. Good customer service and technical support provided by manufacturers is the most significant issue regarding to the life-span of products.

Remark:

All the details of testing and data are for reference only and do not imply any products performance as a result. MTBF is only an estimated date and is depends on both hardware and software. User shall not assume that all the products have the same MTBF as APRO estimates.

2. Product Specifications

For all the following specifications, values are defined at ambient temperature and nominal supply voltage unless otherwise stated.

2.1. System Environmental Specifications

Table 1: Environmental Specification

APRO SLC 1.8" micro SATA III SSD PHANES-K Series		Standard Grade SP8SFxxxG-PKCTC	Industrial Grade WP8SFxxxG-PKITI
Temperature	Operating:	0°C ~ +70°C	-40°C ~ +85°C
	Non-operating:	-20°C ~ +80°C	-50°C ~ +95°C
Humidity	Operating & Non-operating:	10% ~ 95% non-condensing	
Vibration	Frequency/Acceleration:	80 Hz to 2000 Hz, 20G, 3 axes	
Shock	Operating & Non-operating:	0.5ms, 1500 G, 3 axes	
Electrostatic Discharge (ESD)	Temperature:	24°C	
	Relative Humidity:	49% (RH)	
	+/-4KV:	Device functions are affected, but EUT will be back to its normal or operational state automatically.	

2.2. System Power Requirements

Table 2: Power Requirement

APRO SLC 1.8" micro SATA III SSD PHANES-K Series	
DC Input Voltage (VCC)	3.3V +/- 5% (Default) 5V +/- 5% (Option)
Reading Mode :	2,110.0 mW (max.)
Writing Mode :	2,230.0 mW (max.)
Idle Mode :	310.0 mW (max.)

2.3. System Performance

Table 3: System Performances

Data Transfer Mode supporting		Serial ATA Gen-III (6.0Gb/s = 768MB/s)				
Maximum Performance	Capacity	8GB	16GB	32GB	64GB	128GB
	Sequential Read (MB/s)	320.0	540.0	510.0	510.0	470.0
	Sequential Write (MB/s)	70.0	150.0	300.0	310.0	420.0

Note: The performance was measured using CrystalDiskMark by file size 1000MB (QD32).

2.4. System Reliability

Table 4: System Reliability

Wear-leveling Algorithms	Static & Dynamic Wear-leveling	
Bad Block Management	Supportive	
ECC Technology	Hardware design LDPC (Low Density Parity Check)	
Erase counts	NAND SLC Flash Cell Level : 60K P/E Cycles	
TBW (Tera Bytes Written)		
Capacity	32GB	74
	64GB	153
	128GB	325
	256GB	761
	512GB	2,133

Note:

- Client workload by JESD-219A.
- *The endurance of SSD could be varying based on user behavior, NAND endurance cycles, and write amplification factor. It is not guaranteed by flash vendor.*

2.5. Physical Specifications

Refer to Table 5 and see Figure 2 for APRO SLC 1.8" micro SATA III SSD PHANES-K Series physical specifications and dimensions.

Table 5: Physical Specifications of APRO SLC micro SATA III SSD PHANES-K Series

Length:	54.0 mm
Width:	78.5 mm
Thickness:	5.0 mm
Weight:	25g / 0.88 oz.

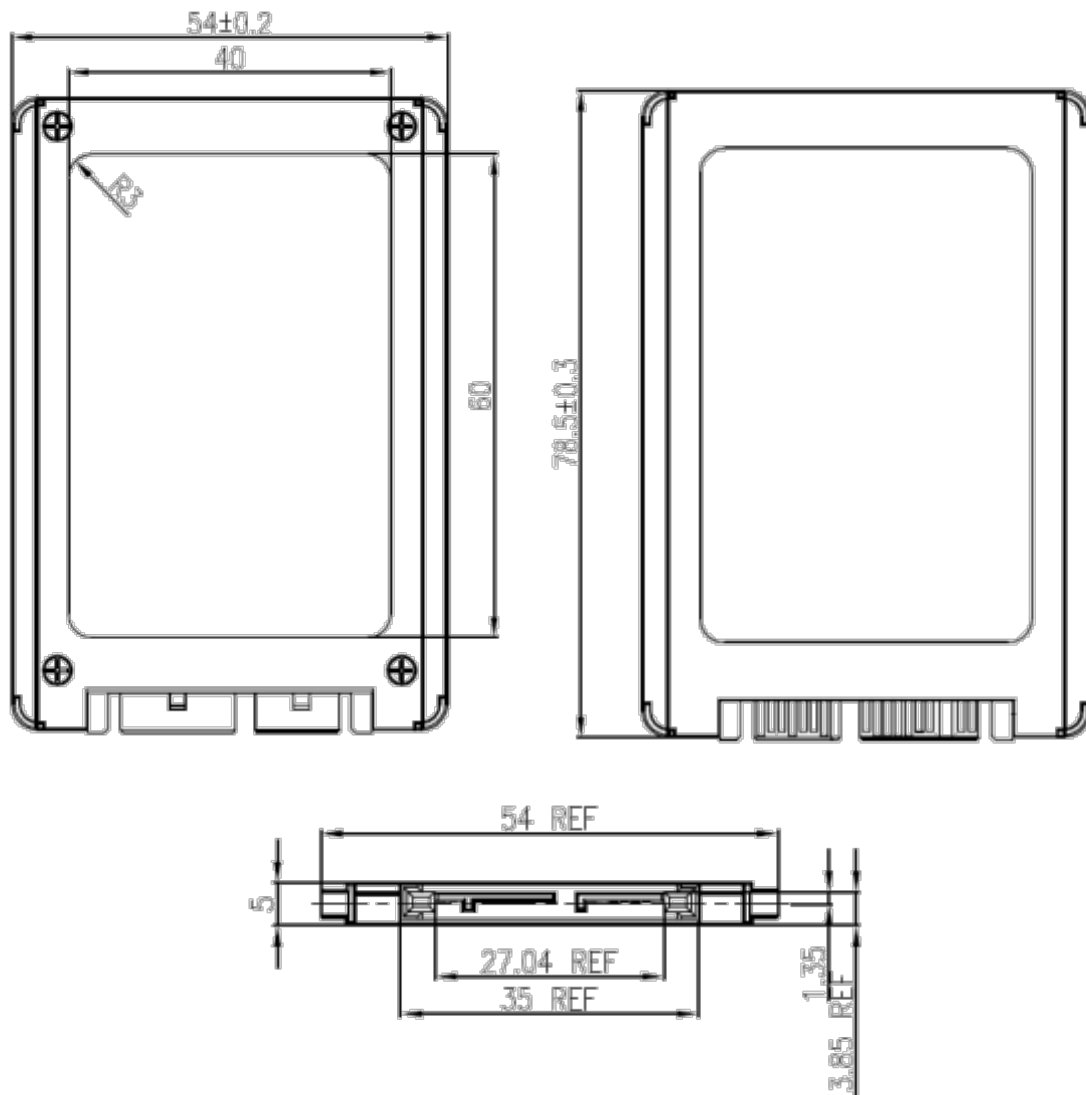

Figure 2: APRO SLC micro SATA III SSD Dimension

2.5.1. Conformal coating

Conformal coating is a protective, dielectric coating designed to conform to the surface of an assembled printed circuit board. Commonly used conformal coatings include silicone, acrylic, urethane and epoxy. APRO applies only silicone on APRO storage products upon requested especially by customers. The type of silicone coating features good thermal shock resistance due to flexibility. It is also easy to apply and repair.

Conformal coating offers protection of circuitry from moisture, fungus, dust and corrosion caused by extreme environments. It also prevents damage from those Flash storages handling during construction, installation and use, and reduces mechanical stress on components and protects from thermal shock. The greatest advantage of conformal coating is to allow greater component density due to increased dielectric strength between conductors.

APRO use MIL-I-46058C silicon conformal coating

3. Interface Description

3.1. micro SATA III SSD interface

Refer to Table 6 and see Figure 3 for APRO 1.8" SLC micro SATA III SSD PHANES-K Series pin assignments.

There are total of 7 pins in the signal segment and 9 pins in the power segment. The pin assignments are listed in below table 6.

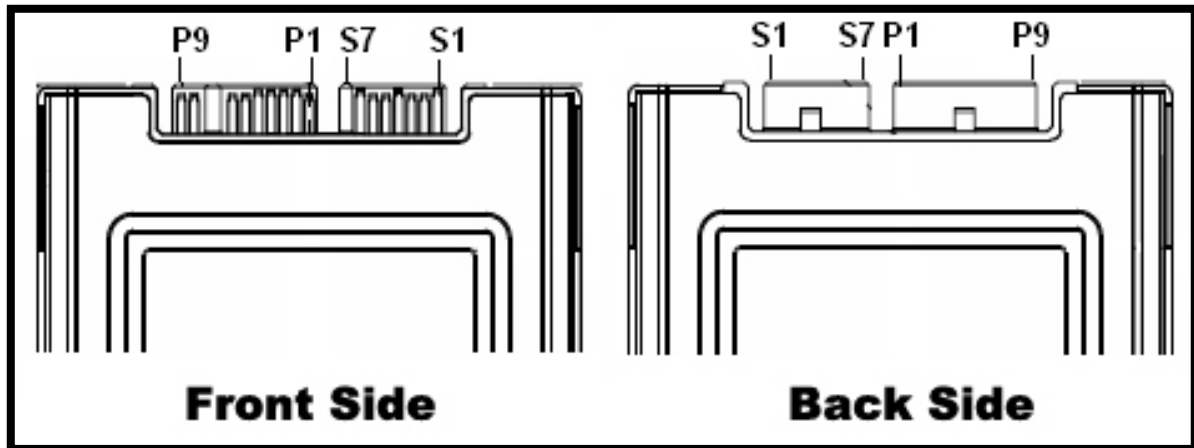

Figure 3: The connectors of SATA 7-pin (data) + 9-pin (power)

3.2. Pin Assignments

APRO SLC 1.8" micro SATA III SSD PHANES-K Series operates with standard SATA pin-out.

The pin assignments are listed in below table 6.

Signal Segment Pin Assignment and Descriptions		
Pin Number	Function	
S1	GND	
S2	A+ (Differential Signal Pair A)	
S3	A – (Differential Signal Pair A)	
S4	GND	
S5	B – (Differential Signal Pair B)	
S6	B+ (Differential Signal Pair B)	
S7	GND	
Power Segment Pin Assignment and Description		
Pin Number	Type	Function
P1	V ₃₃	3.3V Power Input
P2	V ₃₃	3.3V Power Input
P3	GND	GND
P4	GND	GND
P5	V ₅	Reserved for 5V Power Input (Option)
P6	V ₅	Reserved for 5V Power Input (Option)
P7	Optional	Reserved for Active LED (Option)
Key	Key	N/C
P8	Optional	Erase function (Option)
P9	Optional	Reserved (Not Connected)

Table 6 - Pin Assignments

Appendix A: Limited Warranty

APRO warrants your SLC SATA III micro SATA III SSD PHANES-K Series against defects in material and workmanship for the life of the drive. The warranty is void in the case of misuse, accident, alteration, improper installation, misapplication or the result of unauthorized service or repair. The implied warranties of merchantability and fitness for a particular purpose, and all other warranties, expressed or implied, except as set forth in this warranty, shall not apply to the products delivered. In no event shall APRO be liable for any lost profits, lost savings or other incidental or consequential damages arising out of the use of, or inability to use, this product.

BEFORE RETURNING PRODUCT, A RETURN MATERIAL AUTHORIZATION (RMA) MUST BE OBTAINED FROM APRO.

Product shall be returned to APRO with shipping prepaid. If the product fails to conform based on customers' purchasing orders, APRO will reimburse customers for the transportation charges incurred.

WARRANTY PERIOD:

- **SLC STD. Grade 3 years / Within 60K Erasing Counts**
- **SLC IND. Grade 5 years / Within 60K Erasing Counts**

This document is for information use only and is **subject to change without prior notice**. APRO Co., Ltd. assumes no responsibility for any errors that may appear in this document, nor for incidental or consequential damages resulting from the furnishing, performance or use of this material. No part of this document may be reproduced, transmitted, transcribed, stored in a retrievable manner or translated into any language or computer language, in any form or by any means, electronic, mechanical, magnetic, optical, chemical, manual or otherwise, without the prior written consent of an officer of APRO Co., Ltd.

All parts of the APRO documentation are protected by copyright law and all rights are reserved.

APRO and the APRO logo are registered trademarks of APRO Co., Ltd.

Product names mentioned herein are for identification purposes only and may be trademarks and/or registered trademarks of their respective companies.

© 2020 APRO Corporation. All rights reserved